

## Metal Halide Lamps from Heraeus Noblelight for Industrial Applications

Metal halide lamps are mercury medium pressure lamps, where the spectra are matched with the activation spectra of photo-initiators and substrates by the addition of metal halides.

Heraeus Noblelight offers a wide range of standard models from stock. Particular customer requirements can be matched by changing the metal halide content and by designs.

**The lamps find application in a wide range of industries:**

- Reprography
- Photo-chemistry
- Photo-polymerisation
- Curing of paint and lacquers
- Curing of adhesives
- Sewer rehabilitation
- Dental technology

## Variety of Metal Halide Lamps

Heraeus Noblelight offers a wide range of Metal Halide lamps to suit a host of different industrial and scientific applications. In co-operation with customers, Heraeus develops radiation sources, which are specially matched to customers' specifications and processes.

The product range for Metal halide lamps extends from 150 W to 1200 W in various designs. Both standard sockets and customer-specific connectors are available. Consequently, bearing in mind that metal halide lamps can also have various dopings, customers can select UV lamps from a very wide product range to ensure that the one they choose is best suited to their process. This saves energy, maintenance and operating costs and improves quality and process.



Metal halide lamps are most commonly used for applications requiring enhanced spectral outputs.

Available standard spectra.  
Other on request.

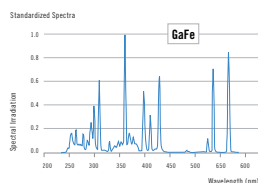
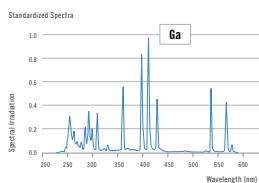
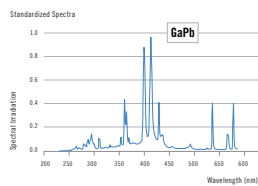
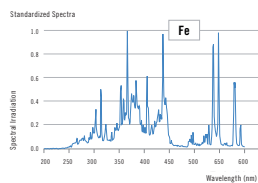

## Typical types of lamps

Lamps and sockets of various designs with a wattage of 100 W up to 8 kW - further configurations on request:

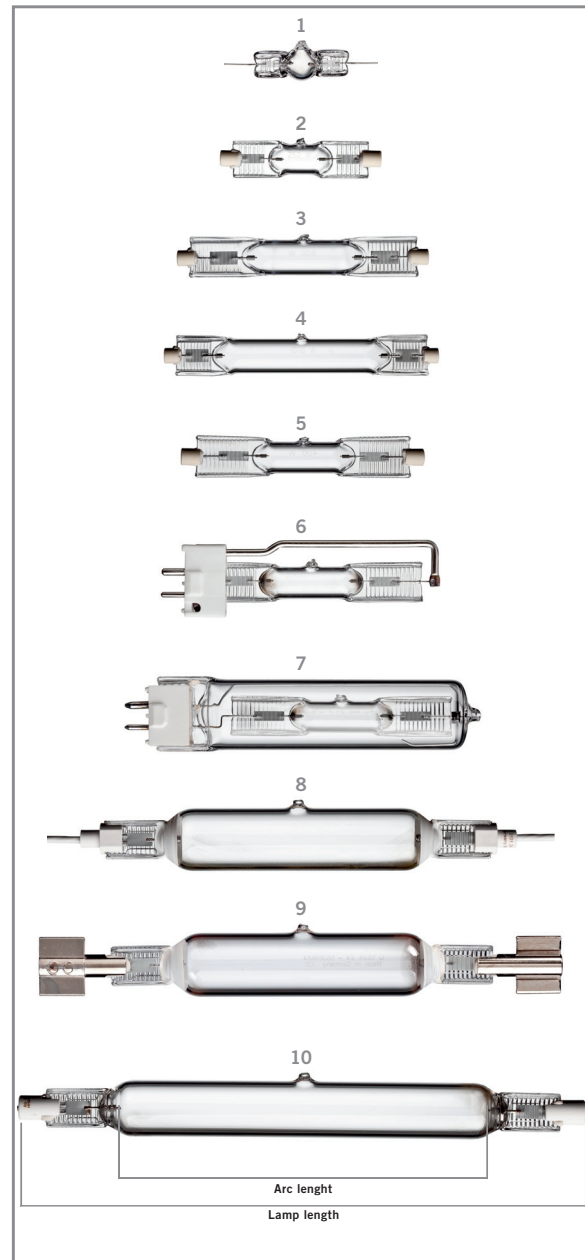

Germany

**Heraeus Noblelight GmbH**  
Heraeusstraße 12-14  
63450 Hanau  
Phone +49 6181 35 9379  
Telefax +49 6181 35 9926  
hng-uv@heraeus.com  
[www.heraeus-noblelight.com](http://www.heraeus-noblelight.com)

France

**Heraeus Noblelight**  
12, av. du Québec - Bât I 2  
B.P. 630 Villebon  
91945 Courtaboeuf Cedex  
Phone +33 (0) 1 69 18 48 51  
Telefax: +33(0) 1 69 28 82 43  
didier.baty@heraeus.com

USA

**Heraeus Noblelight LLC**  
2150 Northmont Parkway  
Duluth, GA 30095  
Phone +1 770 418 0707  
Telefax +1 770 418 0688  
info@noblelight.net

China

**Heraeus Noblelight (Shenyang) Ltd.**  
4F, 11th Building  
No.99 Tianzhou Rd.  
200233 Shanghai  
Phone +86 21 5445 2255  
Telefax +86 21 5445 2410  
info.hns@heraeus.com